

DRAWING MADE IN THIRD ANGLE PROJECTION

THIS DRAWING IS UNPUBLISHED. RELEASED FOR PUBLICATION , 19

REVISIONS						
P	F	ZONE	LTR	DESCRIPTION	DATE	APPROVED
				RELEASE OF NEW PRODUCT	03/93	J.L.M.
✓		A		REV PER ECN 0911-93	08/93	N.G.F.

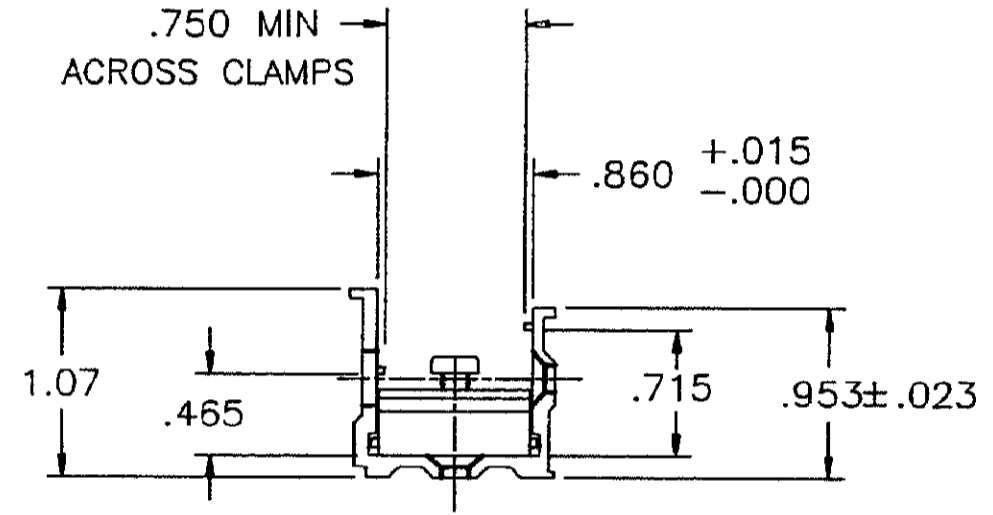
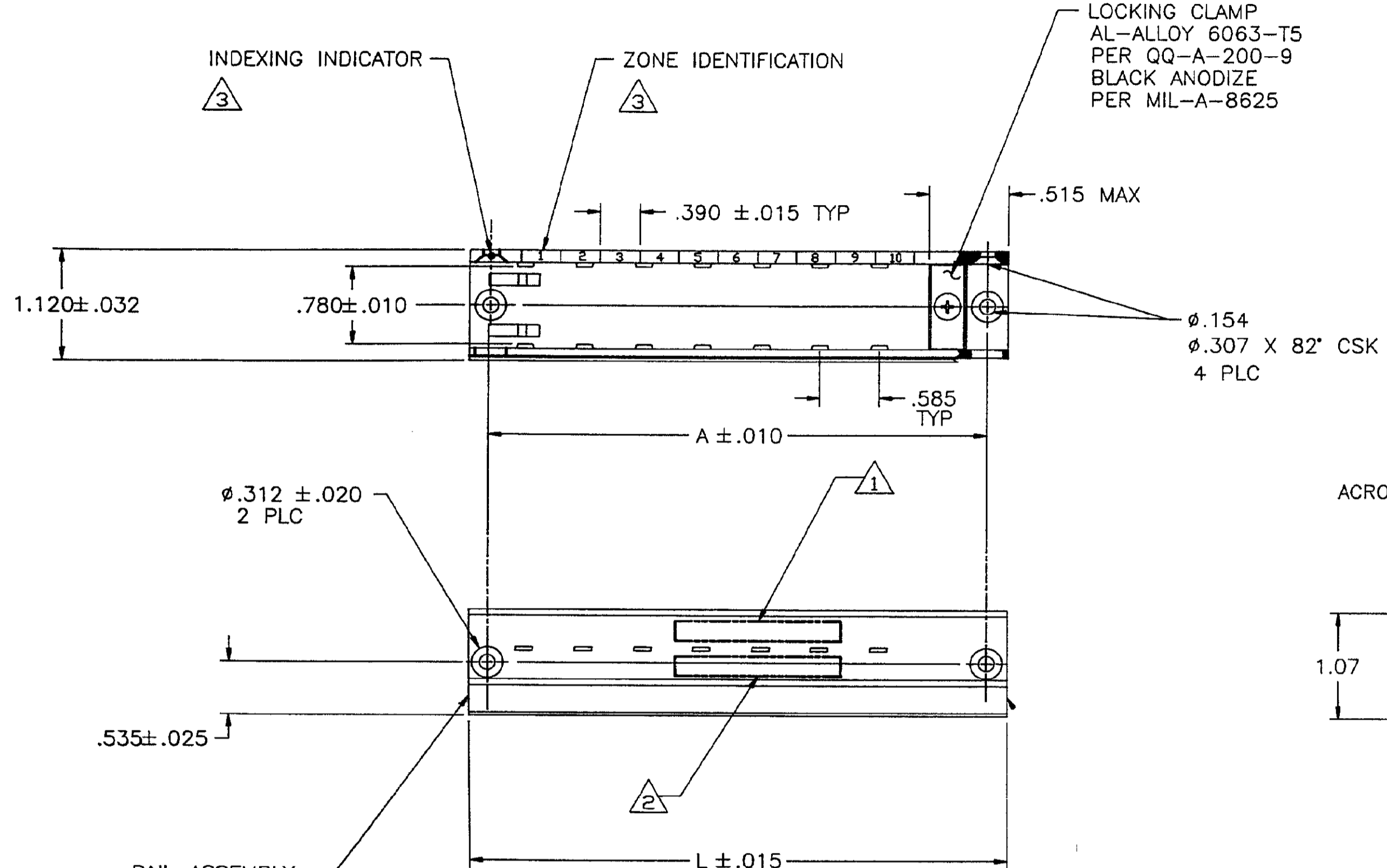

RAIL ASSEMBLY
AL-ALLOY 6063-T5
PER QQ-A-200-9
BLACK ANODIZE
PER MIL-A-8625

4. AMP PART NO.'S 591613-1 THRU 2-591613-0 WERE FORMERLY MATRIX SCIENCE PART NO.'S MRTB-1 THRU MRTB-20.

- ③ MARK RAIL ASSEMBLY WITH INDEXING INDICATOR AND ZONE IDENTIFICATION AT APPROXIMATE AREA SHOWN.
- ② MARK RAIL ASSEMBLY WITH CUSTOMER PART NO. .060 MINIMUM HIGH CHARACTERS AT APPROXIMATE AREA SHOWN.
- ① MARK RAIL ASSEMBLY WITH "AMP", AMP PART NO. AND DATE CODE .060 MINIMUM HIGH CHARACTERS AT APPROXIMATE AREA SHOWN.

CUSTOMER PART NO.	DIM. A	DIM. L	PART NO
MRTB-2	1.671	2.171	2-591613-1
---	8.691	9.191	2-591613-0
---	8.301	8.801	1-591613-9
---	7.911	8.411	1-591613-8
---	7.521	8.021	1-591613-7
---	7.131	7.631	1-591613-6
M81714/5-13	6.741	7.241	1-591613-5
M81714/5-12	6.351	6.815	1-591613-4
M81714/5-11	5.961	6.461	1-591613-3
M81714/5-10	5.571	6.071	1-591613-2
M81714/5-9	5.181	5.681	1-591613-1

CUSTOMER PART NO.	DIM. A	DIM. L	PART NO
M81714/5-1	4.791	5.291	1-591613-0
M81714/5-8	4.401	4.901	591613-9
M81714/5-7	4.011	4.511	591613-8
M81714/5-6	3.621	4.121	591613-7
M81714/5-5	3.231	3.731	591613-6
M81714/5-4	2.841	3.341	591613-5
M81714/5-3	2.451	2.951	591613-4
M81714/5-2	2.061	2.561	591613-3
---	1.671	2.171	591613-2
---	1.281	1.781	591613-1

UNLESS OTHERWISE SPECIFIED DIMENSIONS ARE IN INCHES. TOLERANCES ON: 2 PLC DEC ± .01 3 PLC DEC ± .005 ANGLES ±	CONTRACT NO		AMP INCORPORATED Harrisburg, Pa. 17105	
	DR	N. FRITZ 04-26-93		
	CHK	R. RYAN 03-31-93	NAME RAIL, FEED-BACK ASSEMBLY TJ	
	APPD	R. RYAN 03-31-93		
MATERIAL	APPD	D. ENGLER 03-31-93	SIZE	C
FINISH	DSGN APPD		FSCM NO	00779
	OTHER APPD		DRAWING NO	591613
			SCALE	4 : 1
				SHEET 1 OF 1